



eXtreme pine products for life

Engineering spantables for
bearers and joists

Natural Product

Design Pine is manufactured from Timber which is a natural product and it will react to climatic changes during the life of the product. We attempt to minimise the effect these changes may have on the appearance of the product but resin bleed, raised grain or uneven swelling may occur as a result of climatic conditions. To reduce the risk of adverse effects in the wood fibre we recommend the following guidelines.

Installation requirements:

Follow standard preparation methods for installation of treated timber

1. Ensure the board is equal to the original size or has the correct moisture content (8-14%) prior to installation.
2. All cuts, notches, holes and rebates must be re-coated with an approved preservative sealer (e.g. Tanalised EnSeal or equivalent).
3. Apply a high quality finish either paint or stain as per manufacturers guidelines to give protection from the weather. The of protection could lead to distortion or surface checking.

Paint Colour

If paint is the desired finish ensure a light colour is used. Light colours with a light reflective value (LRV) of >30 or Total Solar Reflectance (TSR) >29 are recommended to prevent heat build up in the board surface.

Fixings

Use only hot dipped galvanised or Stainless steel connector compliant with Australian Standards.

Resin Bleed

Resin is a natural part of timber, when the boards temperature becomes elevated resin may come from timber products. Simply clean off with mineral turps and re apply finish.

eXtreme timber spantables

CONTENTS	PAGE
Floor bearers	4
Floor bearers Double	12
Joists	20
Posts	22
Diagrams	76
Engineer's structural certification	81



The mark of
responsible forestry

Floor bearers

Loads

Floor	0.4 kPa
Live	1.5 kPa
	1.8 kN

Deflection limits

Dead Loads	span/300 or 12mm
Live loads	span/360 or 9mm
	1kN 2mm

Single span

		Verandah width / Joist span				
		1200	1800	2400	3000	
Bearer size						
90 x 70	GL8	1400	1400	1400	1300	
140 x 65	GL8	2200	2200	2200	2000	
190 x 65	GL8	3000	3000	3000	2800	
240 x 65	GL8	3800	3800	3600	3400	
280 x 65	GL8	4400	4200	4000	3900	

Notes

1. Bearers designed to provisions of AS 1720.1:1997, *Timber Structures*.
2. Timber grade GL8 - seasoned, dry use
3. Bearers do not support roof loads.
4. Allowance of 30kg/m for balustrade.
5. Spans may be increased by 10% for bearers continuous over 2 or more spans.

3600	4200	4800	5400	6000
1300	1250	1150	1100	1050
1900	1850	1750	1650	1550
2600	2550	2400	2250	2150
3300	3200	3000	2800	2700
3700	3600	3500	3300	3100

Floor bearers

Loads

Floor	0.4 kPa
Live	2.0 kPa
	1.8 kN

Deflection limits

Dead Loads	span/300 or 12mm
Live loads	span/360 or 9mm
	1kN 2mm

Single span

		Verandah width / Joist span				
		1200	1800	2400	3000	
Bearer size						
90 x 70	GL8	1400	1400	1400	1300	
140 x 65	GL8	2200	2200	2100	1900	
190 x 65	GL8	3000	3000	2800	2600	
240 x 65	GL8	3800	3700	3500	3300	
280 x 65	GL8	4400	4100	3900	3700	

Notes

1. Bearers designed to provisions of AS 1720.1:1997, *Timber Structures*.
2. Timber grade GL8 - seasoned, dry use
3. Bearers do not support roof loads.
4. Allowance of 30kg/m for balustrade.
5. Spans may be increased by 10% for bearers continuous over 2 or more spans.

3600	4200	4800	5400	6000
1200	1100	1050	950	900
1800	1650	1550	1450	1400
2400	2250	2100	2000	1900
3000	2800	2700	2500	2400
3600	3300	3100	2900	2800

Floor bearers

Loads

Floor	0.4 kPa
Live	3.0 kPa
	1.8 kN

Deflection limits

Dead Loads	span/300 or 12mm
Live loads	span/360 or 9mm
	1kN 2mm

Single span

		Verandah width / Joist span				
		1200	1800	2400	3000	
Bearer size						
90 x 70	GL8	1400	1400	1200	1100	
140 x 65	GL8	2200	2100	1800	1600	
190 x 65	GL8	3000	2800	2500	2200	
240 x 65	GL8	3700	3500	3100	2800	
280 x 65	GL8	4200	3900	3600	3300	

Notes

1. Bearers designed to provisions of AS 1720.1:1997, *Timber Structures*.
2. Timber grade GL8 - seasoned, dry use
3. Bearers do not support roof loads.
4. Allowance of 30kg/m for balustrade.
5. Spans may be increased by 10% for bearers continuous over 2 or more spans.

3600	4200	4800	5400	6000
1000	900	850	800	750
1500	1400	1300	1250	1150
2000	1900	1800	1700	1600
2600	2400	2200	2100	2000
3000	2800	2600	2500	2300

Floor bearers

Loads

Floor	0.4 kPa
Live	4.0 kPa
	1.8 kN

Deflection limits

Dead Loads	span/300 or 12mm
Live loads	span/360 or 9mm
	1kN 2mm

Single span

		Verandah width / Joist span				
		1200	1800	2400	3000	
Bearer size						
90 x 70	GL8	1400	1200	1000	900	
140 x 65	GL8	2200	1800	1600	1400	
190 x 65	GL8	3000	2500	2200	1900	
240 x 65	GL8	3600	3200	2700	2500	
280 x 65	GL8	4000	3700	3200	2900	

Notes

1. Bearers designed to provisions of AS 1720.1:1997, *Timber Structures*.
2. Timber grade GL8 - seasoned, dry use
3. Bearers do not support roof loads.
4. Allowance of 30kg/m for balustrade.
5. Spans may be increased by 10% for bearers continuous over 2 or more spans.

	3600	4200	4800	5400	6000
	800	800	750	700	700
	1300	1250	1150	1100	1050
	1800	1650	1550	1500	1400
	2300	2100	2000	1800	1800
	2600	2400	2300	2200	2000

Floor bearers - double

Loads

Floor	0.4 kPa
Live	1.5 kPa
	1.8 kN

Deflection limits

Dead Loads	span/300 or 12mm
Live loads	span/360 or 9mm
	1kN 2mm

Single span

		Verandah width / Joist span				
		1200	1800	2400	3000	
Bearer size						
2/ 90 x 70	GL8	1800	1800	1800	1700	
2/ 140 x 65	GL8	2800	2800	2700	2600	
2/ 190 x 65	GL8	3800	3800	3600	3400	
2/ 240 x 65	GL8	4800	4500	4200	4100	
2/ 280 x 65	GL8	5300	5000	4700	4500	

Notes

1. Bearers designed to provisions of AS 1720.1:1997, *Timber Structures*.
2. Timber grade GL8 - seasoned, dry use
3. Bearers do not support roof loads.
4. Allowance of 30kg/m for balustrade.
5. Spans may be increased by 10% for bearers continuous over 2 or more spans.

3600	4200	4800	5400	6000
1600	1550	1500	1450	1400
2400	2350	2300	2200	2150
3300	3200	3100	3000	2900
3900	3800	3700	3600	3500
4400	4200	4100	4000	3900

Floor bearers - double

Loads

Floor	0.4 kPa
Live	2.0 kPa
	1.8 kN

Deflection limits

Dead Loads	span/300 or 12mm
Live loads	span/360 or 9mm
	1kN 2mm

Single span

		Verandah width / Joist span				
		1200	1800	2400	3000	
Bearer size						
2/ 90 x 70	GL8	1800	1800	1700	1600	
2/ 140 x 65	GL8	2800	2800	2600	2400	
2/ 190 x 65	GL8	3800	3600	3400	3300	
2/ 240 x 65	GL8	4600	4300	4100	3900	
2/ 280 x 65	GL8	5200	4800	4600	4400	

Notes

1. Bearers designed to provisions of AS 1720.1:1997, *Timber Structures*.
2. Timber grade GL8 - seasoned, dry use
3. Bearers do not support roof loads.
4. Allowance of 30kg/m for balustrade.
5. Spans may be increased by 10% for bearers continuous over 2 or more spans.

3600	4200	4800	5400	6000
1500	1500	1400	1350	1300
2300	2250	2150	2100	2000
3200	3050	2950	2850	2700
3800	3600	3500	3500	3400
4200	4100	4000	3900	3800

Floor bearers - double

Loads

Floor	0.4 kPa
Live	3.0 kPa
	1.8 kN

Deflection limits

Dead Loads	span/300 or 12mm
Live loads	span/360 or 9mm
	1kN 2mm

Single span

		Verandah width / Joist span				
		1200	1800	2400	3000	
Bearer size						
2/ 90 x 70	GL8	1800	1700	1600	1500	
2/ 140 x 65	GL8	2800	2600	2400	2300	
2/ 190 x 65	GL8	3700	3400	3200	3100	
2/ 240 x 65	GL8	4400	4100	3900	3700	
2/ 280 x 65	GL8	4900	4600	4300	4100	

Notes

1. Bearers designed to provisions of AS 1720.1:1997, *Timber Structures*.
2. Timber grade GL8 - seasoned, dry use
3. Bearers do not support roof loads.
4. Allowance of 30kg/m for balustrade.
5. Spans may be increased by 10% for bearers continuous over 2 or more spans.

3600	4200	4800	5400	6000
1400	1300	1250	1150	1100
2100	2000	1850	1750	1650
2900	2700	2500	2400	2250
3500	3400	3200	3000	2800
4000	3800	3700	3500	3300

Floor bearers - double

Loads

Floor	0.4 kPa
Live	4.0 kPa
	1.8 kN

Deflection limits

Dead Loads	span/300 or 12mm
Live loads	span/360 or 9mm
	1kN 2mm

Single span

		Verandah width / Joist span				
		1200	1800	2400	3000	
Bearer size						
2/ 90 x 70	GL8	1800	1600	1500	1300	
2/ 140 x 65	GL8	2700	2400	2300	2000	
2/ 190 x 65	GL8	3600	3300	3100	2800	
2/ 240 x 65	GL8	4200	3900	3700	3500	
2/ 280 x 65	GL8	4700	4400	4100	3900	

Notes

1. Bearers designed to provisions of AS 1720.1:1997, *Timber Structures*.
2. Timber grade GL8 - seasoned, dry use
3. Bearers do not support roof loads.
4. Allowance of 30kg/m for balustrade.
5. Spans may be increased by 10% for bearers continuous over 2 or more spans.

3600	4200	4800	5400	6000
1200	1150	1100	1000	950
1900	1750	1650	1550	1450
2500	2350	2200	2100	2000
3200	3000	2800	2600	2500
3700	3500	3200	3100	2900

Joists

Loads

Floor	0.4 kPa
	1.8 kN

Deflection limits

Dead Loads	span/300 or 12mm
Live loads	span/360 or 9mm

1.5 kPa

Single span		Joist spacing mm		
		400	450	600
Joist size				
90 x 70	GL8	1900	1800	1650
140 x 65	GL8	3000	2850	2600
190 x 65	GL8	4200	4000	3650
240 x 65	GL8	5100	4950	4600
280 x 65	GL8	5750	5550	5150

2.0 kPa

Single span		Joist spacing mm		
		400	450	600
Joist size				
90 x 70	GL8	1900	1800	1650
140 x 65	GL8	3000	2850	2600
190 x 65	GL8	4100	3950	3650
240 x 65	GL8	4850	4750	4400
280 x 65	GL8	5450	5300	4950

GL8

Notes

1. Joists designed to provisions of AS 1720.1:1997, *Timber Structures*.
2. Timber grade GL8
3. Spans may be increased by 10% for joists continuous over 2 or more spans.
4. Solid blocking required at midspan and at ends for joists with a span of 2.5m or greater.

3.0 kPa

Single span		Joist spacing mm		
		400	450	600
Joist size				
90 x 70	GL8	1900	1800	1650
140 x 65	GL8	2950	2850	2600
190 x 65	GL8	3800	3700	3450
240 x 65	GL8	4550	4400	4100
280 x 65	GL8	5100	4950	4600

4.0 kPa

Single span		Joist spacing mm		
		400	450	600
Joist size				
90 x 70	GL8	1800	1750	1550
140 x 65	GL8	2750	2650	2350
190 x 65	GL8	3600	3500	3200
240 x 65	GL8	4300	4150	3850
280 x 65	GL8	4800	4650	4350

Posts supporting roof only

Roof weight 6kg/m²

Tributary roof area (m ²)	4	6	8	10	
Post size	Maximum post height (m)				
88 x 88	4.40	4.40	4.40	3.90	
112 x 112	5.60	5.60	5.60	5.60	
135 x 135	6.75	6.75	6.75	6.75	

Roof weight 10kg/m²

Tributary roof area (m ²)	4	6	8	10	
Post size	Maximum post height (m)				
88 x 88	4.40	4.40	4.30	3.70	
112 x 112	5.60	5.60	5.60	5.60	
135 x 135	6.75	6.75	6.75	6.75	

Roof weight 20kg/m²

Tributary roof area (m ²)	4	6	8	10	
Post size	Maximum post height (m)				
88 x 88	4.40	4.40	3.90	3.40	
112 x 112	5.60	5.60	5.60	5.60	
135 x 135	6.75	6.75	6.75	6.75	

12	15	20	25
3.50	3.00	2.40	
5.60	5.20	4.30	3.80
6.75	6.75	6.50	5.70

12	15	20	25
3.30	2.90	2.30	
5.60	5.00	4.20	3.60
6.75	6.75	6.30	5.50

12	15	20	25
3.00	2.60	2.00	
5.20	4.50	3.80	3.20
6.75	6.75	5.70	5.00

Posts supporting roof only

Roof weight 30kg/m²

Tributary roof area (m ²)	4	6	8	10	
Post size	Maximum post height (m)				
88 x 88	4.40	4.20	3.60	3.10	
112 x 112	5.60	5.60	5.60	5.30	
135 x 135	6.75	6.75	6.75	6.75	

Roof weight 40kg/m²

Tributary roof area (m ²)	4	6	8	10	
Post size	Maximum post height (m)				
88 x 88	4.40	3.90	3.30	2.80	
112 x 112	5.60	5.60	5.50	4.90	
135 x 135	6.75	6.75	6.75	6.75	

Roof weight 60kg/m²

Tributary roof area (m ²)	4	6	8	10	
Post size	Maximum post height (m)				
88 x 88	4.30	3.40	2.80	2.40	
112 x 112	5.60	5.60	4.90	4.30	
135 x 135	6.75	6.75	6.75	6.40	

12	15	20	25
2.70	2.30	1.70	
4.70	4.10	3.40	2.80
6.75	6.20	5.20	4.50

12	15	20	25
2.50	2.00	1.50	
4.40	3.80	3.10	2.50
6.50	5.70	4.80	4.10

12	15	20	25
2.00	1.60	1.00	
3.80	3.20	2.50	2.00
5.80	5.00	4.10	3.50

Posts supporting roof only

Roof weight 75kg/m²

Tributary roof area (m ²)	4	6	8	10	
Post size	Maximum post height (m)				
88 x 88	4.00	3.10	2.60	2.10	
112 x 112	5.60	5.30	4.50	3.90	
135 x 135	6.75	6.75	6.70	5.90	

Roof weight 90kg/m²

Tributary roof area (m ²)	4	6	8	10	
Post size	Maximum post height (m)				
88 x 88	3.70	2.80	2.30	1.90	
112 x 112	5.60	4.80	4.10	3.50	
135 x 135	6.75	6.75	6.10	5.40	

12	15	20	25
1.80	1.40		
3.40	2.90	2.20	1.90
5.30	4.60	3.70	3.10

12	15	20	25
1.50	1.00		
3.10	2.50	1.90	1.20
4.80	4.10	3.30	2.70

Posts supporting roof only

Roof weight 6kg/m²

Tributary roof area (m ²)	4	6	8	10	
Post size	Maximum post height (m)				
88 x 88	4.40	4.40	3.50	3.00	
112 x 112	5.60	5.60	5.60	5.20	
135 x 135	6.75	6.75	6.75	6.75	

Roof weight 10kg/m²

Tributary roof area (m ²)	4	6	8	10	
Post size	Maximum post height (m)				
88 x 88	4.40	4.00	3.40	2.90	
112 x 112	5.60	5.60	5.60	5.00	
135 x 135	6.75	6.75	6.75	6.75	

Roof weight 20kg/m²

Tributary roof area (m ²)	4	6	8	10	
Post size	Maximum post height (m)				
88 x 88	4.40	4.00	3.40	2.90	
112 x 112	5.60	5.60	5.60	5.00	
135 x 135	6.75	6.75	6.75	6.75	

12	15	20	25
2.60			
4.60	4.00	3.30	
6.75	6.10	5.10	4.40

12	15	20	25
2.50			
4.50	3.90	3.20	
6.75	5.90	5.00	4.30

12	15	20	25
2.50			
4.50	3.70	2.90	
6.75	5.60	4.70	4.00

Posts supporting roof only

Roof weight 30kg/m²

Tributary roof area (m ²)	4	6	8	10	
Post size	Maximum post height (m)				
88 x 88	4.40	3.60	3.00	2.50	
112 x 112	5.60	5.60	5.10	4.50	
135 x 135	6.75	6.75	6.75	6.75	

Roof weight 40kg/m²

Tributary roof area (m ²)	4	6	8	10	
Post size	Maximum post height (m)				
88 x 88	4.40	3.40	2.80	2.40	
112 x 112	5.60	5.60	4.90	4.30	
135 x 135	6.75	6.75	6.75	6.40	

Roof weight 60kg/m²

Tributary roof area (m ²)	4	6	8	10	
Post size	Maximum post height (m)				
88 x 88	4.00	3.10	2.50	2.10	
112 x 112	5.60	5.30	4.50	3.90	
135 x 135	6.75	6.75	6.70	5.90	

12	15	20	25
2.20	1.80		
4.00	3.40	2.70	2.20
6.10	5.30	4.40	3.70

12	15	20	25
2.00	1.60		
3.80	3.20	2.50	2.00
5.80	5.00	4.20	3.50

12	15	20	25
1.80	1.40		
3.40	2.90	2.20	1.70
5.30	4.60	3.70	3.00

Posts supporting roof only

Roof weight 75kg/m²

Tributary roof area (m ²)	4	6	8	10	
Post size	Maximum post height (m)				
88 x 88	3.80	2.90	2.30	1.90	
112 x 112	5.60	5.00	4.20	3.60	
135 x 135	6.75	6.75	6.40	5.60	

Roof weight 90kg/m²

Tributary roof area (m ²)	4	6	8	10	
Post size	Maximum post height (m)				
88 x 88	3.60	2.70	2.20	1.80	
112 x 112	5.60	4.80	4.00	3.40	
135 x 135	6.75	6.75	6.00	5.30	

12	15	20	25
1.60	1.10		
3.20	2.70	2.00	1.30
5.00	4.30	3.40	2.80

12	15	20	25
1.40			
3.00	2.40	1.80	0.80
4.70	4.00	3.20	2.60

Posts supporting roof only

Roof weight 6kg/m²

Tributary roof area (m ²)	4	6	8	10	
Post size	Maximum post height (m)				
88 x 88	4.20	3.30	2.70		
112 x 112	5.60	5.60	4.70	4.10	
135 x 135	6.75	6.75	6.75	6.20	

Roof weight 10kg/m²

Tributary roof area (m ²)	4	6	8	10	
Post size	Maximum post height (m)				
88 x 88	4.10	3.30	2.60		
112 x 112	5.60	5.60	4.60	4.00	
135 x 135	6.75	6.75	6.75	6.00	

Roof weight 20kg/m²

Tributary roof area (m ²)	4	6	8	10	
Post size	Maximum post height (m)				
88 x 88	4.00	3.10	2.50		
112 x 112	5.60	5.60	4.40	3.80	
135 x 135	6.75	6.75	6.60	5.80	

12	15	20	25
3.60	3.10		
5.60	4.80	4.00	

12	15	20	25
3.50	3.00		
5.50	4.70	3.90	

12	15	20	25
3.40	2.80		
5.20	4.50	3.70	

Posts supporting roof only

Roof weight 30kg/m²

Tributary roof area (m ²)	4	6	8	10	
Post size	Maximum post height (m)				
88 x 88	3.80	2.90	2.40		
112 x 112	5.60	5.00	4.30	3.70	
135 x 135	6.75	6.75	6.40	5.60	

Roof weight 40kg/m²

Tributary roof area (m ²)	4	6	8	10	
Post size	Maximum post height (m)				
88 x 88	3.70	2.80	2.30	1.80	
112 x 112	5.60	4.80	4.10	3.50	
135 x 135	6.75	6.75	6.20	5.40	

Roof weight 60kg/m²

Tributary roof area (m ²)	4	6	8	10	
Post size	Maximum post height (m)				
88 x 88	3.40	2.60	2.10	1.60	
112 x 112	5.60	4.60	3.80	3.20	
135 x 135	6.75	6.75	5.80	5.10	

12	15	20	25
3.20	2.70		
5.00	4.30	3.50	

12	15	20	25
3.00	2.50		
4.80	4.20	3.30	2.70

12	15	20	25
2.80	2.30		
4.50	3.80	3.00	2.40

Posts supporting roof only

Roof weight 75kg/m²

Tributary roof area (m ²)	4	6	8	10	
Post size	Maximum post height (m)				
88 x 88	3.30	2.50	1.90	1.50	
112 x 112	5.50	4.40	3.60	3.10	
135 x 135	6.75	6.50	5.50	4.80	

Roof weight 90kg/m²

Tributary roof area (m ²)	4	6	8	10	
Post size	Maximum post height (m)				
88 x 88	3.10	2.30	1.80	1.40	
112 x 112	5.30	4.20	3.40	3.10	
135 x 135	6.75	6.30	5.30	4.60	

12	15	20	25
2.60	2.10		
4.30	3.60	2.80	2.10

12	15	20	25
2.40	1.90		
4.00	3.40	2.60	1.90

Posts supporting roof only

Roof weight 6kg/m²

Tributary roof area (m ²)	2	4	6	8	
Post size	Maximum post height (m)				
88 x 88	4.40	3.30	3.50		
112 x 112	5.60	5.60	4.50	3.70	
135 x 135	6.75	6.75	6.70	5.70	

Roof weight 10kg/m²

Tributary roof area (m ²)	2	4	6	8	
Post size	Maximum post height (m)				
88 x 88	4.40	3.30	2.50		
112 x 112	5.60	5.60	4.40	3.70	
135 x 135	6.75	6.75	6.60	5.60	

Roof weight 20kg/m²

Tributary roof area (m ²)	2	4	6	8	
Post size	Maximum post height (m)				
88 x 88	4.40	3.20	2.40		
112 x 112	5.60	5.50	4.30	3.50	
135 x 135	6.75	6.75	6.40	5.40	

10	12	15	20
3.20			
4.90	4.40	3.70	

10	12	15	20
3.00			
4.90	4.30	3.60	

10	12	15	20
3.00			
4.70	4.20	3.50	

Posts supporting roof only

Roof weight 30kg/m²

Tributary roof area (m ²)	2	4	6	8	
Post size	Maximum post height (m)				
88 x 88	4.40	3.10	2.30		
112 x 112	5.60	5.30	4.20	3.40	
135 x 135	6.75	6.75	6.30	5.30	

Roof weight 40kg/m²

Tributary roof area (m ²)	2	4	6	8	
Post size	Maximum post height (m)				
88 x 88	4.40	3.00	2.20		
112 x 112	5.60	5.20	4.00	3.30	
135 x 135	6.75	6.75	6.10	5.10	

Roof weight 60kg/m²

Tributary roof area (m ²)	2	4	6	8	
Post size	Maximum post height (m)				
88 x 88	4.40	2.80	2.10		
112 x 112	5.60	4.90	3.80	3.10	
135 x 135	6.75	6.75	5.80	4.90	

10	12	15	20
2.90			
4.60	4.00	3.40	

10	12	15	20
2.80			
4.40	3.90	3.30	0.00

10	12	15	20
2.60			
4.20	3.70	3.00	

Posts supporting roof only

Roof weight 75kg/m²

Tributary roof area (m ²)	2	4	6	8	
Post size	Maximum post height (m)				
88 x 88	4.20	2.70	2.00		
112 x 112	5.60	4.80	3.70	3.00	
135 x 135	6.75	6.75	5.60	4.70	

Roof weight 90kg/m²

Tributary roof area (m ²)	2	4	6	8	
Post size	Maximum post height (m)				
88 x 88	4.10	2.60	1.90		
112 x 112	5.60	4.60	3.50	2.80	
135 x 135	6.75	6.75	5.50	4.50	

10	12	15	20
2.40	2.00		
4.00	3.50	2.90	

10	12	15	20
2.30	1.90		
3.90	3.30	2.70	

Posts supporting roof only

Roof weight 6kg/m²

Tributary roof area (m ²)	2	4	6	8	
Post size	Maximum post height (m)				
88 x 88	4.30	2.70			
112 x 112	5.60	4.80	3.70		
135 x 135	6.75	6.75	5.70	4.50	

Roof weight 10kg/m²

Tributary roof area (m ²)	2	4	6	8	
Post size	Maximum post height (m)				
88 x 88	4.20	2.70			
112 x 112	5.60	4.70	3.70		
135 x 135	6.75	6.75	5.60	4.70	

Roof weight 20kg/m²

Tributary roof area (m ²)	2	4	6	8	
Post size	Maximum post height (m)				
88 x 88	4.10	2.60			
112 x 112	5.60	4.60	3.60		
135 x 135	6.75	6.75	5.50	4.60	

10	12	15	20
4.00			

10	12	15	20
4.00			

10	12	15	20
3.90			

Posts supporting roof only

Roof weight 30kg/m²

Tributary roof area (m ²)	2	4	6	8	
Post size	Maximum post height (m)				
88 x 88	4.10	2.60			
112 x 112	5.60	4.50	3.50		
135 x 135	6.75	6.75	5.40	4.50	

Roof weight 40kg/m²

Tributary roof area (m ²)	2	4	6	8	
Post size	Maximum post height (m)				
88 x 88	4.00	2.50	0.00		
112 x 112	5.60	4.50	3.40	2.60	
135 x 135	6.75	6.70	5.30	4.30	

Roof weight 60kg/m²

Tributary roof area (m ²)	2	4	6	8	
Post size	Maximum post height (m)				
88 x 88	3.80	2.40			
112 x 112	5.60	4.30	3.20	2.50	
135 x 135	6.75	6.40	5.00	4.20	

10	12	15	20
3.80			

10	12	15	20
3.70	2.50		

10	12	15	20
3.50	3.00		

Posts supporting roof only

Roof weight 75kg/m²

Tributary roof area (m ²)	2	4	6	8	
Post size	Maximum post height (m)				
88 x 88	3.70	2.30			
112 x 112	5.60	4.10	3.10	2.40	
135 x 135	6.75	6.30	4.90	4.00	

Roof weight 90kg/m²

Tributary roof area (m ²)	2	4	6	8	
Post size	Maximum post height (m)				
88 x 88	3.60	2.10			
112 x 112	5.60	4.00	3.00	2.30	
135 x 135	6.75	6.10	4.80	3.90	

10	12	15	20
3.40	2.90		

10	12	15	20
3.20	2.70		

Posts supporting verandah deck (timber floor) and roof

Floor live load 1.5kPa

Allows for snow loads up to 0.5kPa.

Roof weight 10kg/m²

Tributary floor area (m ²)	3	4	5	6	
Post size	Maximum post height (m)				
88 x 88	2.90	2.40	1.80		
112 x 112	5.10	4.20	3.70	3.20	
135 x 135	6.75	6.50	5.70	5.10	

Roof weight 20kg/m²

Tributary floor area (m ²)	3	4	5	6	
Post size	Maximum post height (m)				
88 x 88	2.80	2.30	1.80	0.00	
112 x 112	5.00	4.10	3.60	3.10	
135 x 135	6.75	6.30	5.50	4.90	

Roof weight 30kg/m²

Tributary floor area (m ²)	3	4	5	6	
Post size	Maximum post height (m)				
88 x 88	2.70	2.20	1.70		
112 x 112	4.80	4.00	3.40	3.00	
135 x 135	6.75	6.10	5.30	4.80	

Post height is measured from connection at base to floor bearer connection point.

7	8	9	10	12
2.80	2.50			
4.60	4.20	3.80	3.50	2.10

7	8	9	10	12
2.70	2.40	0.00		
4.40	4.00	3.70	3.30	2.80

7	8	9	10	12
2.60	2.30			
4.30	3.90	3.50	3.20	2.70

Posts supporting verandah deck (timber floor) and roof

Floor live load 1.5kPa

Allows for snow loads up to 0.5kPa.

Roof weight 40kg/m²

Tributary floor area (m ²)	3	4	5	6	
Post size	Maximum post height (m)				
88 x 88	2.60	2.10	1.60		
112 x 112	4.70	3.90	3.30	2.90	
135 x 135	6.75	5.90	5.20	4.60	

Roof weight 60kg/m²

Tributary floor area (m ²)	3	4	5	6	
Post size	Maximum post height (m)				
88 x 88	2.40	1.90			
112 x 112	4.40	3.60	3.10	2.60	
135 x 135	6.60	5.60	4.90	4.30	

Roof weight 75kg/m²

Tributary floor area (m ²)	3	4	5	6	
Post size	Maximum post height (m)				
88 x 88	2.30	1.80			
112 x 112	4.20	3.50	2.90	2.50	
135 x 135	6.40	5.40	4.70	4.20	

Post height is measured from connection at base to floor bearer connection point.

7	8	9	10	12
2.50	2.20			
4.10	3.70	3.40	3.10	2.60

7	8	9	10	12
2.30	2.00			
3.90	3.50	3.20	2.90	2.30

7	8	9	10	12
2.10	1.80			
3.70	3.30	3.00	2.70	2.20

Posts supporting verandah deck (timber floor) and roof

Floor live load 1.5kPa

Allows for snow loads up to 0.5kPa.

Roof weight 90kg/m²

Tributary floor area (m ²)	3	4	5	6	
Post size	Maximum post height (m)				
88 x 88	2.20				
112 x 112	4.10	3.30	2.80	2.40	
135 x 135	6.20	5.20	4.50	4.00	

Post height is measured from connection at base to floor bearer connection point.

7	8	9	10	12
2.00				
3.60	3.20	2.90	2.60	

Posts supporting verandah deck (timber floor) and roof

Floor live load 2 kPa

Allows for snow loads up to 0.5kPa.

Roof weight 10kg/m²

Tributary floor area (m ²)	3	4	5	6	
Post size	Maximum post height (m)				
88 x 88	2.50	2.00	1.50		
112 x 112	4.50	3.70	3.20	2.70	
135 x 135	6.75	5.80	5.00	4.40	

Roof weight 20kg/m²

Tributary floor area (m ²)	3	4	5	6	
Post size	Maximum post height (m)				
88 x 88	2.40	1.90	1.40	0.00	
112 x 112	4.40	3.60	3.10	2.60	
135 x 135	6.60	5.60	4.90	4.30	

Roof weight 30kg/m²

Tributary floor area (m ²)	3	4	5	6	
Post size	Maximum post height (m)				
88 x 88	2.40	1.80	1.30		
112 x 112	4.30	3.50	3.00	2.50	
135 x 135	6.50	5.50	4.70	4.20	

Post height is measured from connection at base to floor bearer connection point.

7	8	9	10	12
2.30	2.00			
3.90	3.50	3.20	2.90	2.30

7	8	9	10	12
2.20	1.90	0.00		
3.80	3.40	3.10	2.80	2.20

7	8	9	10	12
2.10	1.80			
3.70	3.30	3.00	2.70	2.10

Posts supporting verandah deck (timber floor) and roof

Floor live load 2 kPa

Allows for snow loads up to 0.5kPa.

Roof weight 40kg/m²

Tributary floor area (m ²)	3	4	5	6	
Post size	Maximum post height (m)				
88 x 88	2.30	1.70	1.20		
112 x 112	4.20	3.40	2.90	2.40	
135 x 135	6.30	5.30	4.60	4.10	

Roof weight 60kg/m²

Tributary floor area (m ²)	3	4	5	6	
Post size	Maximum post height (m)				
88 x 88	2.10	1.60			
112 x 112	4.00	3.20	2.70	2.20	
135 x 135	6.10	5.10	4.40	3.80	

Roof weight 75kg/m²

Tributary floor area (m ²)	3	4	5	6	
Post size	Maximum post height (m)				
88 x 88	2.00	1.50			
112 x 112	3.80	3.10	2.50	2.10	
135 x 135	5.90	4.90	4.20	3.70	

Post height is measured from connection at base to floor bearer connection point.

7	8	9	10	12
2.00	1.70			
3.60	3.20	2.90	2.60	2.00

7	8	9	10	12
1.90	1.40			
3.40	3.00	2.70	2.40	1.70

7	8	9	10	12
1.70	1.20			
3.20	2.90	2.50	2.20	1.40

Posts supporting verandah deck (timber floor) and roof

Floor live load 2 kPa

Allows for snow loads up to 0.5kPa.

Roof weight 90kg/m²

Tributary floor area (m ²)	3	4	5	6	
Post size	Maximum post height (m)				
88 x 88	1.90				
112 x 112	3.70	3.00	2.40	2.00	
135 x 135	5.70	4.80	4.10	3.50	

Post height is measured from connection at base to floor bearer connection point.

7	8	9	10	12
1.60				
3.10	2.70	2.40	2.10	

Posts supporting verandah deck (timber floor) and roof

Floor live load 3 kPa

Allows for snow loads up to 0.5kPa.

Roof weight 10kg/m²

Tributary floor area (m ²)	3	4	5	6	
Post size	Maximum post height (m)				
88 x 88	1.90	1.30			
112 x 112	3.70	2.90	2.40	1.90	
135 x 135	5.70	4.70	4.00	3.50	

Roof weight 20kg/m²

Tributary floor area (m ²)	3	4	5	6	
Post size	Maximum post height (m)				
88 x 88	1.80	1.20			
112 x 112	3.60	2.90	2.30	1.80	
135 x 135	5.60	4.60	3.90	3.40	

Roof weight 30kg/m²

Tributary floor area (m ²)	3	4	5	6	
Post size	Maximum post height (m)				
88 x 88	1.80	1.10	0.00		
112 x 112	3.50	2.80	2.20	1.80	
135 x 135	5.50	4.50	3.80	3.30	

Post height is measured from connection at base to floor bearer connection point.

7	8	9	10	12
1.40				
3.00	2.60	2.20	1.80	

7	8	9	10	12
1.20				
2.90	2.50	2.10	1.70	

7	8	9	10	12
1.10				
2.80	2.40	2.00	1.50	

Posts supporting verandah deck (timber floor) and roof

Floor live load 3 kPa

Allows for snow loads up to 0.5kPa.

Roof weight 40kg/m²

Tributary floor area (m ²)	3	4	5	6	
Post size	Maximum post height (m)				
88 x 88	1.70	1.00			
112 x 112	3.40	2.70	2.20	1.70	
135 x 135	5.40	4.40	3.70	3.20	

Roof weight 60kg/m²

Tributary floor area (m ²)	3	4	5	6	
Post size	Maximum post height (m)				
88 x 88	1.60	0.70			
112 x 112	3.30	2.60	2.00	1.50	
135 x 135	5.20	4.20	3.60	3.00	

Roof weight 75kg/m²

Tributary floor area (m ²)	3	4	5	6	
Post size	Maximum post height (m)				
88 x 88	1.50				
112 x 112	3.20	2.50	1.90	1.30	
135 x 135	5.00	4.10	3.50	2.90	

Post height is measured from connection at base to floor bearer connection point.

7	8	9	10	12
2.70	2.30	1.90	1.30	

7	8	9	10	12
2.60	2.20	1.70		

7	8	9	10	12
2.50	2.10	1.40		

Posts supporting verandah deck (timber floor) and roof

Floor live load 3 kPa

Allows for snow loads up to 0.5kPa.

Roof weight 90kg/m²

Tributary floor area (m ²)	3	4	5	6	
Post size	Maximum post height (m)				
88 x 88	1.40				
112 x 112	3.10	2.40	1.80	1.00	
135 x 135	4.90	4.00	3.30	2.80	

Post height is measured from connection at base to floor bearer connection point.

7	8	9	10	12
2.40	1.90	1.20		

Posts supporting verandah deck (timber floor) and roof

Floor live load 4 kPa

Allows for snow loads up to 0.5kPa.

Roof weight 10kg/m²

Tributary floor area (m ²)	3	4	5	6	
Post size	Maximum post height (m)				
88 x 88	1.40				
112 x 112	3.10	2.30	1.80		
135 x 135	4.90	4.00	3.30	2.70	

Roof weight 20kg/m²

Tributary floor area (m ²)	3	4	5	6	
Post size	Maximum post height (m)				
88 x 88	1.40				
112 x 112	3.00	2.30	1.70		
135 x 135	4.80	3.90	3.20	2.70	

Roof weight 30kg/m²

Tributary floor area (m ²)	3	4	5	6	
Post size	Maximum post height (m)				
88 x 88	1.30				
112 x 112	2.90	2.20	1.60		
135 x 135	4.70	3.80	3.10	2.60	

Post height is measured from connection at base to floor bearer connection point.

7	8	9	10	12
2.30	1.70			

7	8	9	10	12
2.20	1.60			

7	8	9	10	12
2.10	1.40			

Posts supporting verandah deck (timber floor) and roof

Floor live load 4 kPa

Allows for snow loads up to 0.5kPa.

Roof weight 40kg/m²

Tributary floor area (m ²)	3	4	5	6	
Post size	Maximum post height (m)				
88 x 88	1.30				
112 x 112	2.90	2.20	1.50		
135 x 135	4.60	3.70	3.10	2.50	

Roof weight 60kg/m²

Tributary floor area (m ²)	3	4	5	6	
Post size	Maximum post height (m)				
88 x 88	1.10				
112 x 112	2.80	2.00	1.30		
135 x 135	4.50	3.60	2.90	2.40	

Roof weight 75kg/m²

Tributary floor area (m ²)	3	4	5	6	
Post size	Maximum post height (m)				
88 x 88	1.00				
112 x 112	2.70	2.00	1.10		
135 x 135	4.40	3.50	2.80	2.30	

Post height is measured from connection at base to floor bearer connection point.

7	8	9	10	12
2.00	1.30			

7	8	9	10	12
1.90				

7	8	9	10	12
1.70				

Posts supporting verandah deck (timber floor) and roof

Floor live load 4 kPa

Allows for snow loads up to 0.5kPa.

Roof weight 90kg/m²

Tributary floor area (m ²)	3	4	5	6	
Post size	Maximum post height (m)				
88 x 88	0.80				
112 x 112	2.60	1.90			
135 x 135	4.30	3.40	2.80	2.20	

Post height is measured from connection at base to floor bearer connection point.

7	8	9	10	12
1.50				

Diagrams

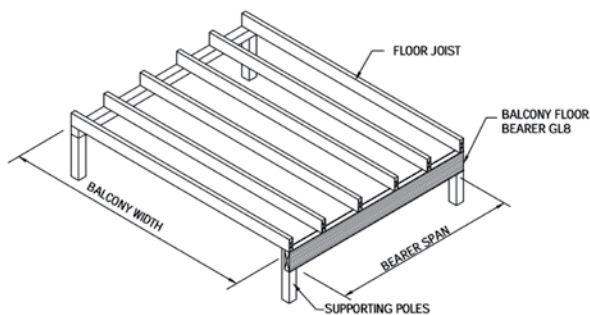

deck bearer

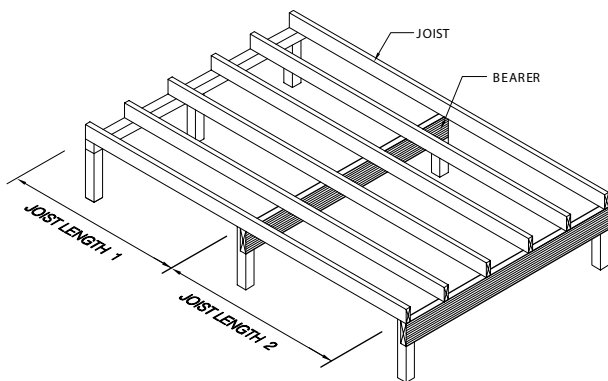

JOIST SPAN TO CENTRAL BEARER = JOIST LENGTH 1 + JOIST LENGTH 2

floor or deck bearer

Diagrams

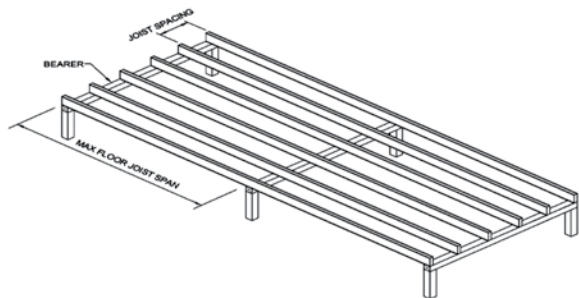

deck joists

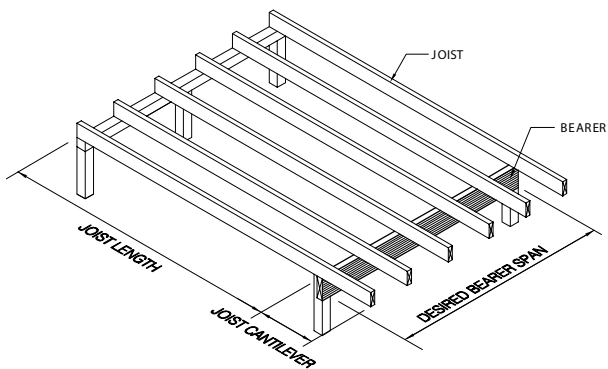

JOIST SPAN TO CENTRAL BEARER = JOIST LENGTH + CANTILEVER

floor or deck bearer with cantilever joist

Diagrams

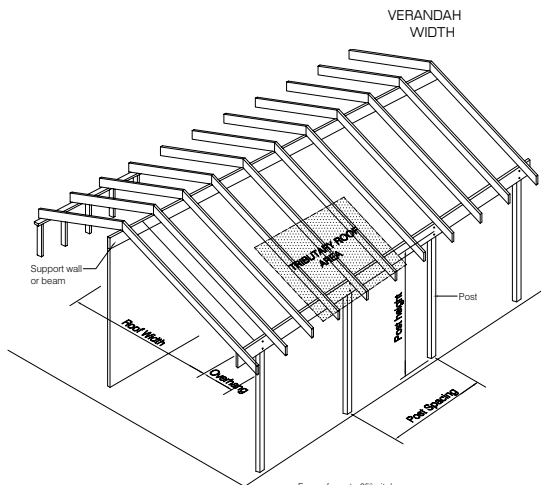

For roofs up to 25° pitch:
Tributary roof area = (Roof width / 2 + overhang) x post spacing.

For roofs over 25° pitch use slope length of rafter to determine roof width.

Post height is measured from base to centreline of fixings at top.

posts

STRUCTURAL CERTIFICATION

SPAN TABLES FOR eXtreme timber range of products

Including

Bearers, floor joists, posts, rafters and verandah beams

eXtreme timber - www.extremetimber.com.au

I, David J King being a Chartered Professional Engineer and currently holding an Annual Practising Certificate, certify that the span tables have been prepared using widely accepted engineering principles.

Design loads and deflection criteria have been determined from AS/NZS 1170.0:2002, AS/NZS 1170.1:2002 *Structural Design Actions* and AS4055-2006 *Wind loads for housing*.

Structural design is to the requirements of AS1720.1:1997 *Timber Structures* for seasoned timber.



David King

ME (civil) MIPENZ

CPEng (no. 145511) New Zealand

IntPE (NZ)

10 October 2012

Ron O'Hara BE (Civil) MIPENZ
David King ME (Civil) MIPENZ CPEng IntPE

PO Box 3631, Richmond
Nelson 7050, New Zealand

Phone +64 3 544 8404

Fax +64 3 544 8694

Email admin@tcae.co.nz





The mark of
responsible forestry

www.extremetimber.com.au